

Dimensions of the Lumiglas Mini-Luminaire Stainless Steel, Model USL 01:

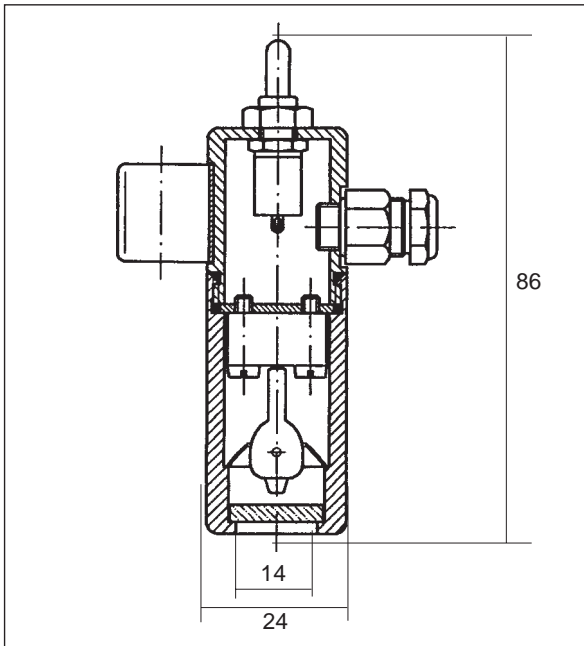

Material and Parts:

- Body and head: stainless steel 1.4305.
- Mounting bracket: Stainless steel (both for hinged version and SW1 wiper clamp).
- Connecting cable: 3 m (3 x 0.5 mm²).
- Weight: appx. 0.150 kg.

Power Connecting Data:

Lumiglas Mini-Luminaire Stainless Steel, USL 01			
Item	Model USL 01	Cat. No. ¹⁾	Supply V
1	(12 V) 5 W without p. button	3540.001.00	12
2	(24 V) 20 W with push button	3540.002.00	24

¹⁾ = Ordering No.

Replacement Parts		
Halogen Filament Lamps		
Socket	Power	Cat. No. ¹⁾
G 4	12 V/5 W	3232.221.00
G 4	24 V/20 W	3232.206.00

Mounting Bracket:

- mounting clamp (included in supply)
- hinged bracket Cat. No.¹⁾ 3540.002.00

Ordering Specifications (example):

- Lumiglas Mini Luminaire Model Stainless Steel, Model USL 01, 24 V/20 W with push button, Cat. No. 3540.002.00 and in addition, if required:
- Hinged mounting bracket.

Example of fastening:

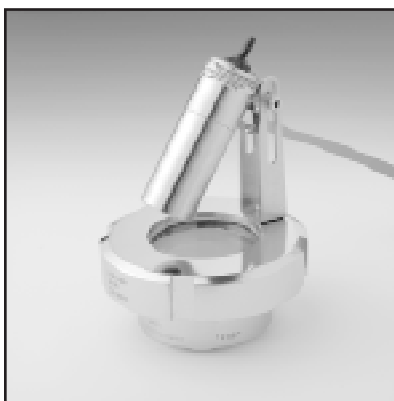

Lighting port assembly, showing Lumiglas Mini -Luminaire Stainless Steel, Model USL 01, with hinged bracket fitted to screwed sightglass (MV 50).

All dimensions in mm unless stated otherwise. Subject to change without prior notice

BD 2000/09.00 3755.272

LJSTAR

INCORPORATED

PO Box 1116 • Twinsburg, OH 44087 • (330) 405-3040 • Fax 405-3070

E-mail: view@ljstar.com • Website: www.ljstar.com